



# LEHENGOMAK, S.p.A.

## Valvole elettriche *Electric valves*

Valvola elettrica 2 vie unidirezionale pilotata - a cartuccia mod. EV25-C .....	pag. 4
<i>Two ways pilot operated electric valve - cartridge style mod. EV25-C .....</i>	<i>pag. 4</i>
Valvola elettrica 2 vie unidirezionale pilotata mod. EV25, EV25VE .....	pag. 5
<i>Two ways pilot operated electric valve mod. EV25, EV25VE .....</i>	<i>pag. 5</i>
Valvola elettrica 2 vie unidirezionale pilotata - a cartuccia mod. EV40-C .....	pag. 7
<i>Two ways pilot operated electric valve - cartridge style mod. EV40-C .....</i>	<i>pag. 7</i>
Valvola elettrica 2 vie unidirezionale pilotata mod. EV40, EV40VE .....	pag. 8
<i>Two ways pilot operated electric valve mod. EV40, EV40VE .....</i>	<i>pag. 8</i>
Valvola elettrica 2 vie unidirezionale pilotata - a cartuccia mod. EV70-C .....	pag. 10
<i>Two ways pilot operated electric valve - cartridge style mod. EV70-C .....</i>	<i>pag. 10</i>
Valvola elettrica 2 vie unidirezionale pilotata mod. EV70, EV70VE .....	pag. 11
<i>Two ways pilot operated electric valve mod. EV70, EV70VE .....</i>	<i>pag. 11</i>
Valvola elettrica 2 vie unidirezionale pilotata - a cartuccia mod. EV150-C .....	pag. 13
<i>Two ways pilot operated electric valve - cartridge style mod. EV150-C .....</i>	<i>pag. 13</i>
Valvola elettrica 2 vie unidirezionale pilotata mod. EV150, EV150VE .....	pag. 14
<i>Two ways pilot operated electric valve mod. EV150, EV150VE .....</i>	<i>pag. 14</i>



## Ordinazioni

Gli ordini devono essere inviati alla:

### **CBF S.r.l.**

Via Caboto, 1  
36075 Montecchio Maggiore (VI)  
Tel. 0444 499141-3  
Fax 0444 499145

Per posta o telefax. Si prega di evitare, ove possibile, di effettuare ordini per telefono dato che questi dovranno essere in ogni caso confermati per lettera o fax.

### **Gli ordini devono chiaramente indicare:**

- Esatta ragione sociale o indirizzo completo del richiedente.
- Numero d'ordine.
- Data d'ordine.
- Numero d'offerta **CBF** (qualora esista).
- Denominazione valvola.
- Data consegna richiesta.
- Destinazione merce.
- Vettore.

## Garanzia

- La **CBF S.r.l.** garantisce che i suoi prodotti sono esenti da difetti di materiali o di costruzione per un periodo di 12 mesi a partire dalla data di spedizione dai propri magazzini in Montecchio Maggiore (VI) - Italia.
- La garanzia è esclusivamente limitata alla riparazione o sostituzione, a giudizio della **CBF S.r.l.**, d'ogni parte o parti difettose in materiale o costruzione, previo esame dei pezzi che devono essere ritornati alla **CBF**, franco destino, corredati di descrizione dettagliata del malfunzionamento.
- **CBF** declina ogni responsabilità ed esclude l'applicazione della garanzia per quei prodotti che, a proprio insindacabile giudizio, siano stati contaminati, impiegati erroneamente o manomessi in circostanze al di fuori del proprio controllo o senza autorizzazione. La garanzia decade qualora siano apportate modifiche a circuiti o impianti tali da influenzare negativamente il funzionamento del prodotto **CBF**.
- In nessun caso una rivalsa in garanzia potrà comportare revoche contrattuali, sospensioni anche parziali di pagamenti, compensi per danni o rimborsi spese, ivi compresa la spesa di manodopera per la sostituzione del pezzo.
- Questa garanzia riconosciuta dalla **CBF S.r.l.** attraverso la propria organizzazione assistenziale esclude e sostituisce ogni altra garanzia di qualsiasi genere.
- **CBF S.r.l.** non è responsabile per danni diretti o indiretti, ivi comprese eventuali perdite economiche conseguenti a fermo macchina, o ritardate consegne di qualsiasi genere.

## Responsabilità d'uso.

Tutti i prodotti **CBF** sono sottoposti a rigorosi collaudi funzionali, conformemente alle caratteristiche riportate sulla documentazione tecnica **CBF**.

Dal momento che le reali condizioni di funzionamento delle apparecchiature del Compratore non sono riproducibili integralmente nei laboratori della **CBF**, la responsabilità della scelta e l'idoneità dei prodotti sono a carico del Compratore stesso.

## Giurisdizione

In caso di contestazione in cui la **CBF S.r.l.** sia convenuta è esclusivamente competente il Foro di Vicenza. Le tratte, le accettazioni di regolamenti, le spedizioni senza o contrassegno, le esazioni per mezzo d'incaricati, non costituiscono deroga a questa clausola anche nel caso in cui la **CBF S.r.l.** fosse ricercata per connessione o continenza di causa.

Quando la **CBF S.r.l.** sia attrice potrà ricorrere sia al Foro di Vicenza, sia a quello di residenza del convenuto.



## Order entry procedure.

Orders are received by:

### **CBF S.r.l.**

Via Caboto, 1  
36075 Montecchio Maggiore (VI)  
Tel. ++39-0444-499141/3  
Fax ++39-0444-499145

By mail or telefax. When possible, please avoid sending orders by telephone since you must later confirm them by letter.

### **Orders must clearly show:**

- The corporate name and the full address of the applicant.
- Order number.
- Order date.
- **CBF's** offer number (when existing).
- Valve denomination.
- Required delivery date.
- Goods destination.
- Carrier.

### **Warranty**

- **CBF S.r.l.** warrants that its products are free from defects in material and workmanship for a period of 12 months from the date of shipment from the factory in Montecchio Maggiore (VI) - Italy.
- The warranty is strictly limited to the repair or replacement (at **CBF S.r.l.** option) of any part or parts defective in material or workmanship, subject to **CBF's** examination of the part which must be returned to **CBF S.r.l.**, carriage pre-paid by the Customer, with a detailed description of the malfunction.
- **CBF S.r.l.** shall not be responsible for circumstances beyond its control and this warranty shall not apply to products which, in the sole judgement of **CBF** have been subjected to contamination, tampering, negligent handling, misapplication or other misuse. Changes in circuit or changes in other components which may adversely affect the products of **CBF S.r.l.** void this warranty.
- In none of the cases quoted in the above paragraphs can the customer claim the cancellation of the contract compensation for damages or reimbursement of any expenses as, for example, labor required to replace the defective parts.
- This warranty recognized by **CBF S.r.l.** through its service organization is expressly in lieu of and excludes and supersedes any warranty of merchantability or fitness.
- **CBF S.r.l.** makes no other warranties, expressed or implied, and is not responsible for any consequential damages resulting from use by any buyer or user, its liability being limited to the value of product sold or to the obligation to replace a defective part. In no event shall **CBF S.r.l.** be liable for loss of anticipated profits, consequential damages, or loss of any equipment, installation, system operation or service into which the products of **CBF S.r.l.** may be fitted. **CBF S.r.l.** shall not be liable for any default, claimed breach of warranty, failure to deliver or otherwise, except as herein specifically indicated.

### **Responsibility for use.**

All **CBF** products are checked and tested, in accordance with the specifications indicated in the relevant technical documents. Since the actual installation and performance of the Customer's equipment cannot be exactly reproduced in the **CBF** testing laboratories, the assurance of suitability of all **CBF's** products in the Customer application is the responsibility of the Customer himself.

### **Jurisdiction**

In case of a dispute where **CBF S.r.l.** is summoned before court, the Court in Law in Vicenza (Italy) is exclusively competent: drafts, acceptance of settlements, dispatches without or with C.O.D. do not constitute a derogation from this clause of jurisdiction even in case **CBF S.r.l.** should be pursued for concession or contenance of cause.

When **CBF S.r.l.** is the plaintiff, it will be able to recur both to Court of Law in Vicenza and to that where the other party resides.

**Valvola elettrica 2 vie unidirezionale pilotata - a cartuccia**  
**Two ways pilot operated electric valve - cartridge style**  
**mod. EV25 - C**

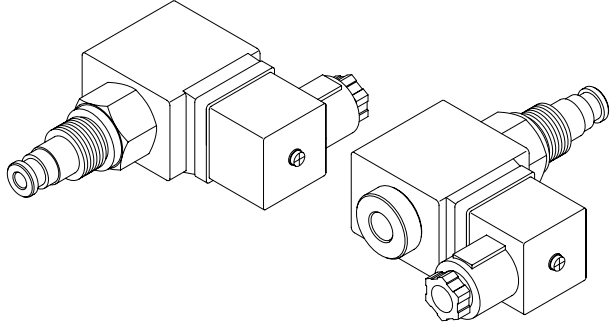

Cod.	Schema Symbol	Funzioni possibili con solenoide: Operating features with solenoid:	
		diseccitato de-energized	eccitato energized
<b>A</b>		P → A A → P	P → A A → P
<b>B</b>		P → A A → P	P → A A → P

Schema idraulico / Hydraulic scheme

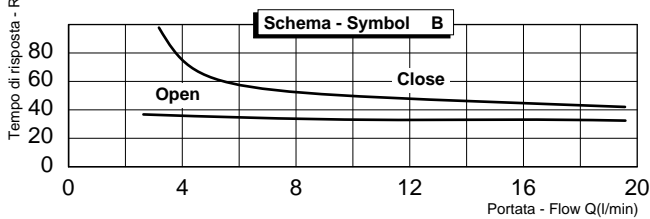
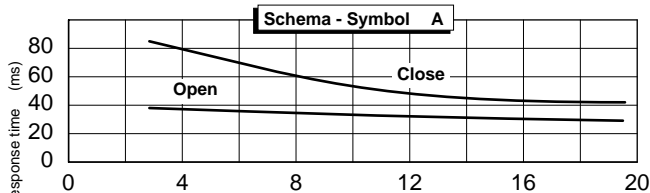
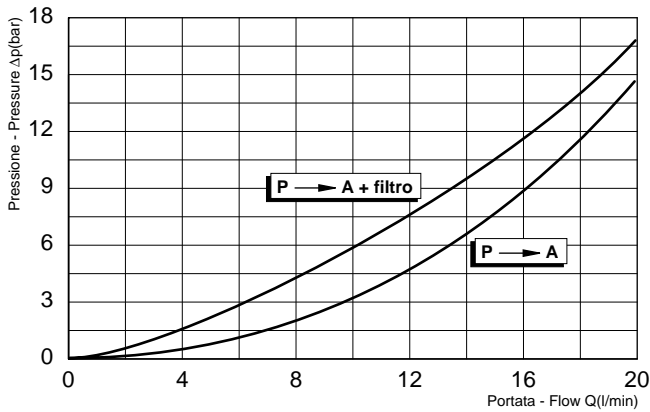

Tutti i dati forniti sono stati ottenuti usando olio con viscosità di circa 30 cSt a 50 °C. Campo di temperatura ammesso: -20 °C, +90 °C. Filtrazione assoluta: 25µ.  
 I dati non sono impegnativi, **CBF** si riserva di apportare modifiche senza preavviso.

*All performances and calibrations are carried out by using hydraulic oil with viscosity approx. 30 cSt at 50 °C. Temperature range: -20 °C, +90 °C. Filtration absolute: 25µ.  
 The specifications are not binding, **CBF** reserves the right to introduce modifications without notice.*

Modello EV25-C Type EV25-C	Pressione massima Max pressure bar	Portata max Max flow l / min
Schema - Symbol A	250	25
Schema - Symbol B	210	

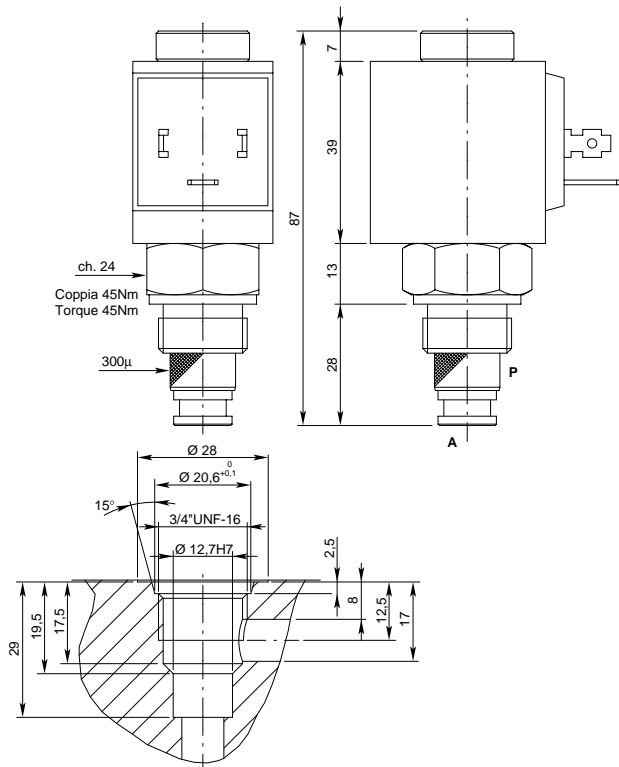

**Sigla di ordinazione / Ordering code**

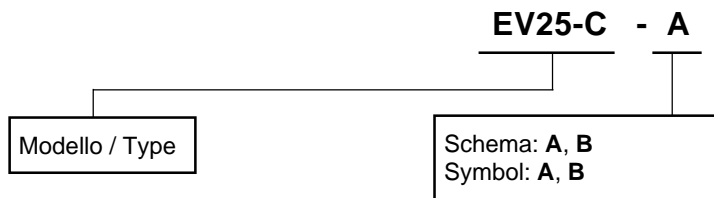



**Valvola elettrica 2 vie unidirezionale pilotata con o senza vite di emergenza**  
**Two ways pilot operated electric valve with or without emergency screw**  
**mod. EV25 / EV25VE**

Cod.	Schema Symbol	Funzioni possibili con solenoide: Operating features with solenoid:	
		diseccitato de-energized	eccitato energized
<b>A</b>		P → A A → P	P → A A → P
<b>B</b>		P → A A → P	P → A A → P

Schema idraulico / Hydraulic scheme

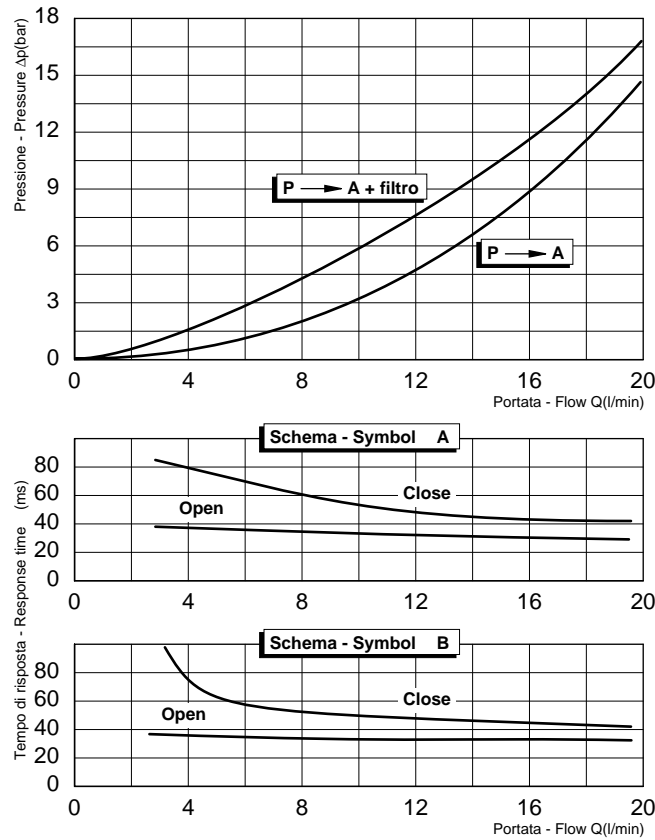

Tutti i dati forniti sono stati ottenuti usando olio con viscosità di circa 30 cSt a 50 °C. Campo di temperatura ammesso: -20 °C, +90 °C. Filtrazione assoluta: 25µ.  
 All performances and calibrations are carried out by using hydraulic oil with viscosity approx. 30 cSt at 50 °C. Temperature range: -20 °C, +90 °C. Filtration absolute: 25µ.

Modello Type	P A	Pressione massima Max pressure bar	Portata max Max flow l / min
EV25 - 14 / EV25 - 14 - VE	1/4" gas	250	25
EV25 - 38 / EV25 - 38 - VE	3/8" gas		

Disegni / Drawings

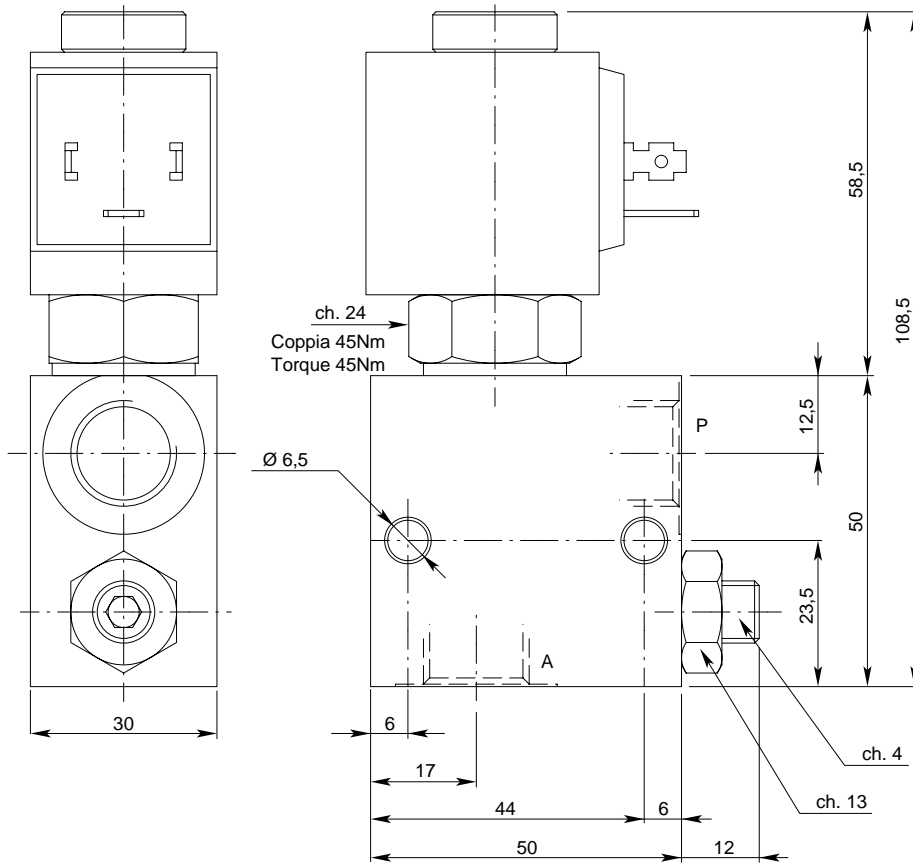

Sigla di ordinazione / Ordering code

**EV25 - 14 - A - VE**

Modello / Type

I dati non sono impegnativi, **CBF** si riserva di apportare modifiche senza preavviso.  
The specifications are not binding, **CBF** reserves the right to introduce modifications without notice.

Válvula eléctrica 2 vías unidireccional pilotada - a cartucho  
 Two ways pilot operated electric valve - cartridge style  
 mod. EV40 - C

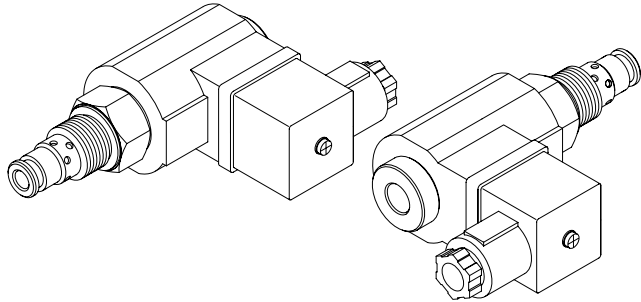

Cod.	Esquema Symbol	Función posible con solenoide: Operating features with solenoid:	
		desenergizado de-energized	energizado energized
<b>A</b>		P → A A → P	P → A A → P
<b>B</b>		P → A A → P	P → A A → P
<b>M</b>		P → A A → P	P → A A → P

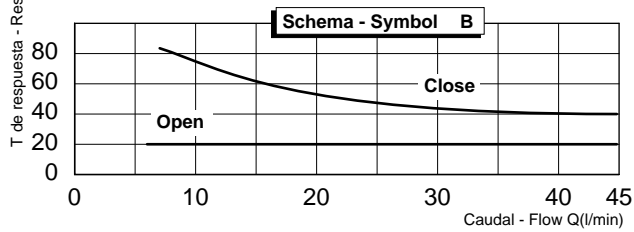
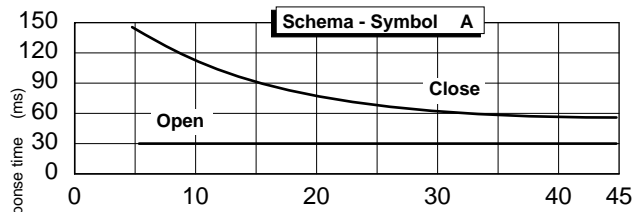
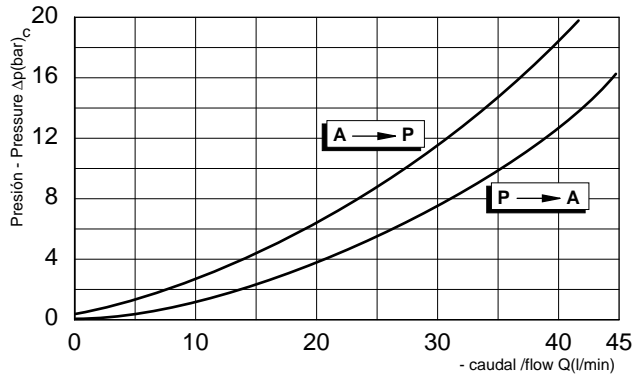

Modelo EV40-C Type EV40-C	Presión máxima Max pressure bar	Caudal max Max flow l / min
Esquema - Symbol A	300	45
Esquema - Symbol B		
Esquema - Symbol C		

Codificación pedido / Ordering code

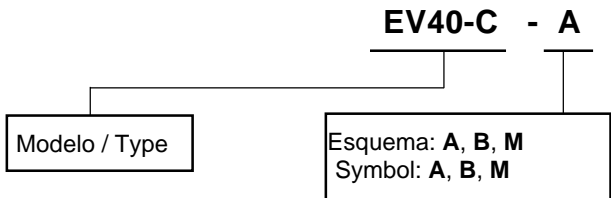

Todos los datos y calibraciones han sido obtenidos con aceite 30 cSt a 50 °C. Campo de temperatura admisible: -20 °C, +90 °C. Filtración absoluta: 25µ.  
 los datos no son imperativos, CBF se reserva el derecho a modificaciones sinb previo aviso.  
 .All performances and calibrations are carried out by using hydraulic oil with viscosity approx. 30 cSt at 50 °C. Temperature range: -20 °C, +90 °C. Filtration absolute: 25µ.  
 The specifications are not binding, CBF reserves the right to introduce modifications without notice.

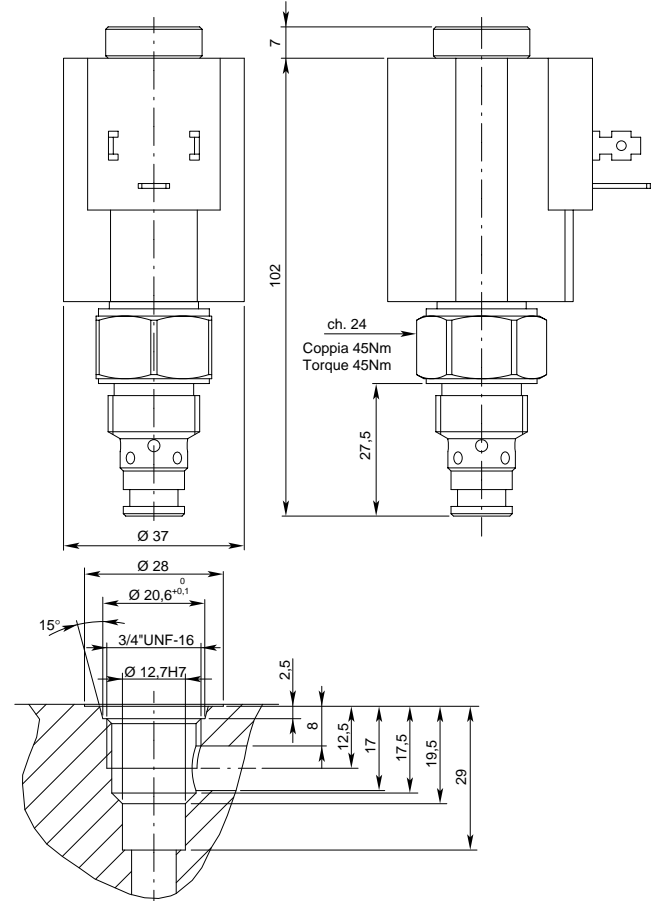

**Válvula eléctrica 2 vías unidireccional pilotada con o sin accionamiento de emergencia**  
**Two ways pilot operated electric valve with or without emergency screw**  
**mod. EV40 / EV40VE**

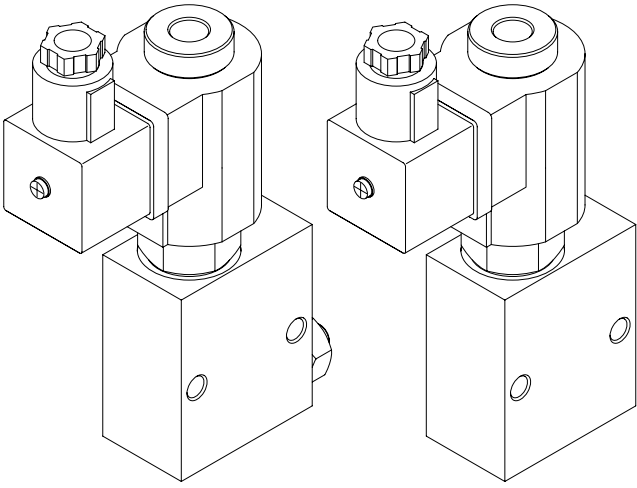

Cod.	Esquema Symbol	Función posible con solenoide: Operating features with solenoid:	
		desescitado de-energized	escitado energized
<b>A</b>		P → A	P → A
		A → P	A → P
<b>B</b>		P → A	P → A
		A → P	A → P

Esquema hidráulico / Hydraulic scheme

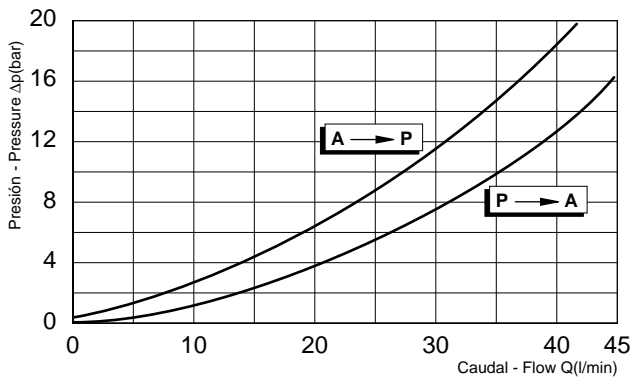

Todos los datos y calibraciones han sido obtenidos con aceite de 30 cSt a 50 °C. Campo de temperatura admisible: -20 °C, +90 °C. Filtración absoluta: 25µ.  
*All performances and calibrations are carried out by using hydraulic oil with viscosity approx. 30 cSt at 50 °C. Temperature range: -20 °C, +90 °C. Filtration absolute: 25µ.*

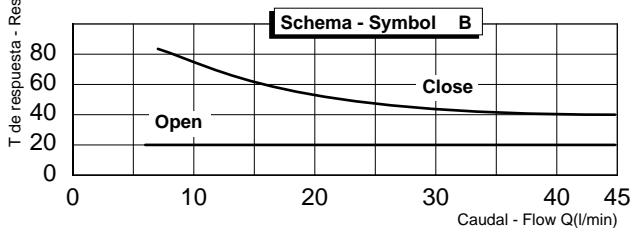
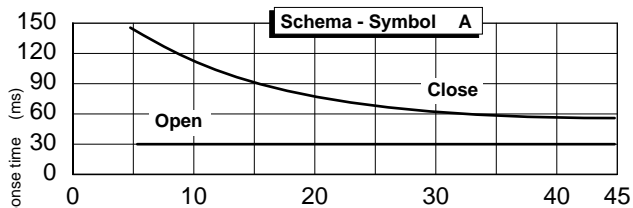

Modello Type	P A	Pressione massima Max pressure bar	Portata max Max flow l / min
EV40 - 38 / EV40 - 38 - VE	3/8" gas	300	45
EV40 - 12 / EV40 - 12 - VE	1/2" gas		



## Diseño / Drawings

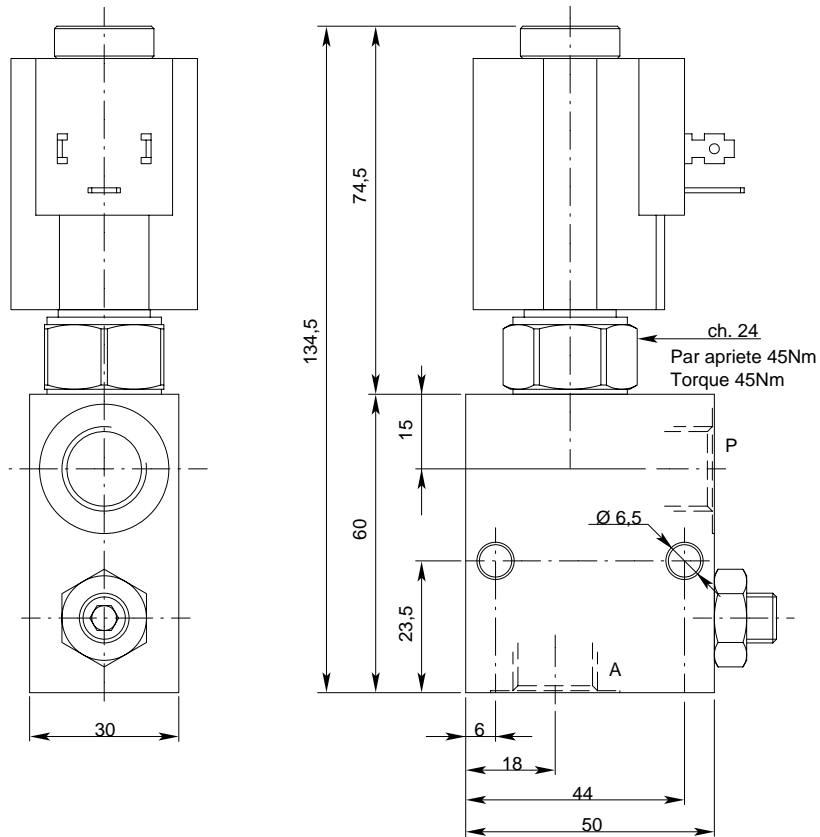

## Codificación de pedido / Ordering code

**EV40 - 12 - B - VE**

Modelo / Type

Los datos no son imperativos, **CBF** se reserva el derecho de modificar sin previo aviso.  
The specifications are not binding, **CBF** reserves the right to introduce modifications without notice.

**Valvola elettrica 2 vie unidirezionale pilotata - a cartuccia**  
**Two ways pilot operated electric valve - cartridge style**  
**mod. EV70 - C**

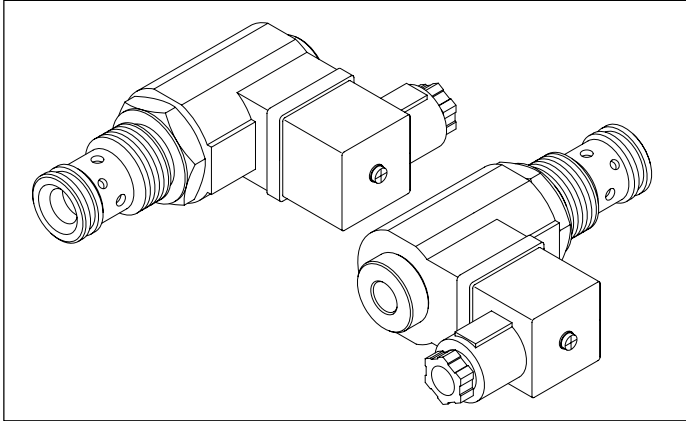

Cod.	Schema Symbol	Funzioni possibili con solenoide: Operating features with solenoid:	
		diseccitato de-energized	eccitato energized
<b>A</b>		P → A A → P	P → A A → P
<b>B</b>		P → A A → P	P → A A → P
<b>M</b>		P → A A → P	P → A A → P

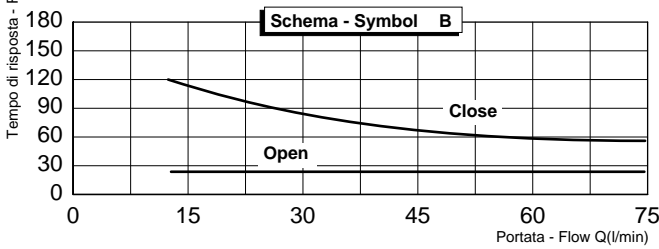
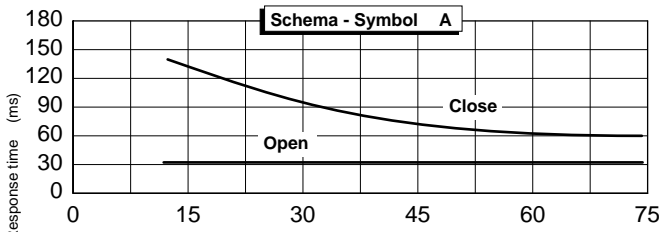
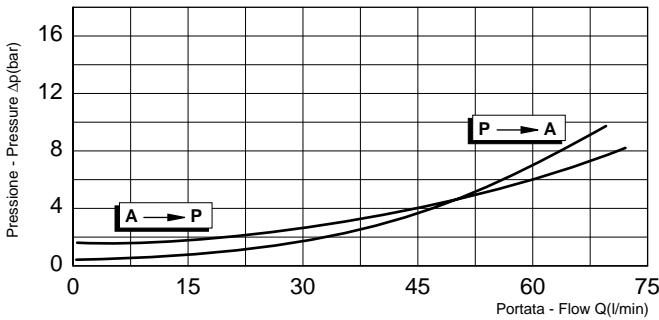

Tutti i dati forniti sono stati ottenuti usando olio con viscosità di circa 30 cSt a 50 °C. Campo di temperatura ammesso: -20 °C, +90 °C. Filtrazione assoluta: 25µ.  
 I dati non sono impegnativi, CBF si riserva di apportare modifiche senza preavviso.  
 All performances and calibrations are carried out by using hydraulic oil with viscosity approx. 30 cSt at 50 °C. Temperature range: -20 °C, +90 °C. Filtration absolute: 25µ.  
 The specifications are not binding, CBF reserves the right to introduce modifications without notice.

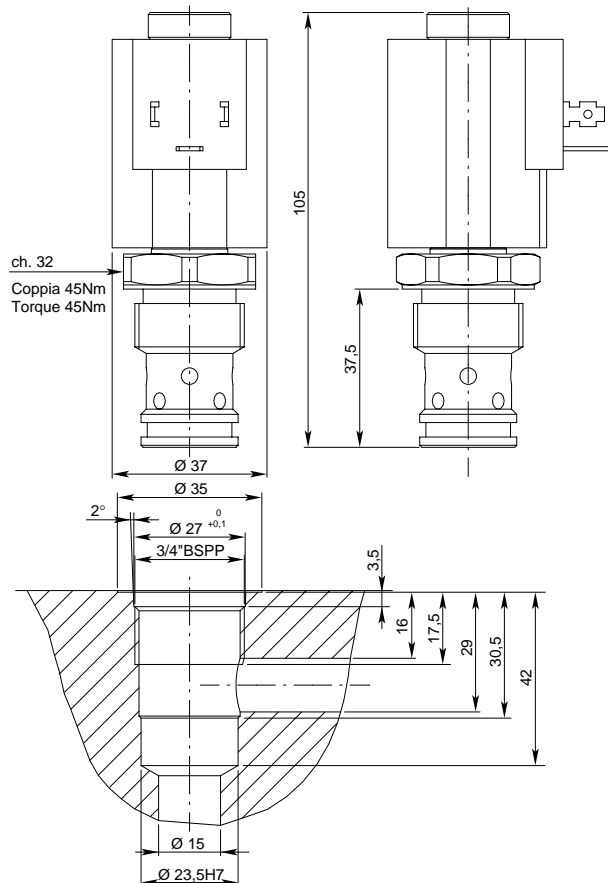

Modello EV70-C Type EV70-C	Pressione massima Max pressure bar	Portata max Max flow l / min
Schema - Symbol A	300	70
Schema - Symbol B		

**Sigla di ordinazione / Ordering code**

**EV70-C - A**

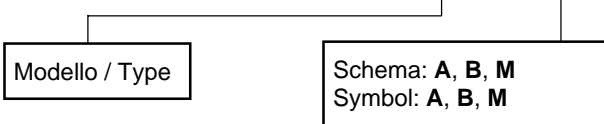



**Valvola elettrica 2 vie unidirezionale pilotata con o senza vite di emergenza**  
**Two ways pilot operated electric valve with or without emergency screw**  
**mod. EV70 / EV70VE**

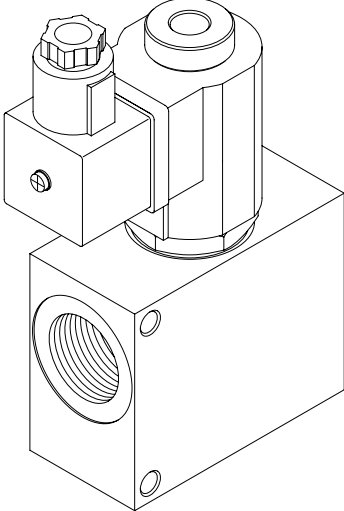

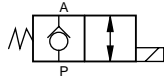
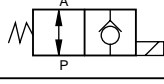
Cod.	Schema Symbol	Funzioni possibili con solenoide: Operating features with solenoid:	
		diseccitato de-energized	eccitato energized
<b>A</b>		P  A A → P	P → A A → P
<b>B</b>		P → A A → P	P  A A → P

Schema idraulico / Hydraulic scheme

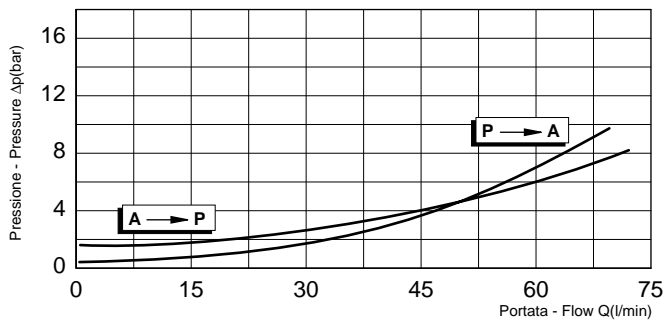

Tutti i dati forniti sono stati ottenuti usando olio con viscosità di circa 30 cSt a 50 °C. Campo di temperatura ammesso: -20 °C, +90 °C. Filtrazione assoluta: 25µ.  
 All performances and calibrations are carried out by using hydraulic oil with viscosity approx. 30 cSt at 50 °C. Temperature range: -20 °C, +90 °C. Filtration absolute: 25µ.

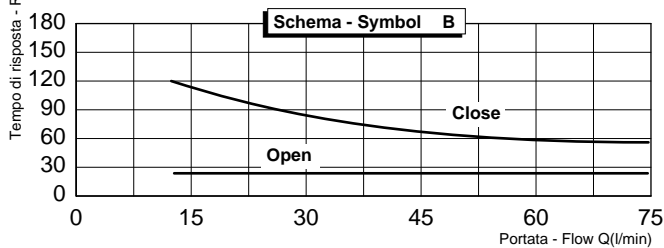
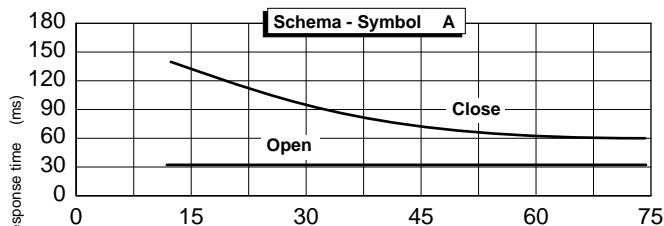

Modello Type	P A	Pressione massima Max pressure bar	Portata max Max flow l / min
EV70 - 12 / EV70 - 12 - VE	1/2" gas	300	70
EV70 - 34 / EV70 - 34 - VE	3/4" gas		

**Disegni / Drawings**

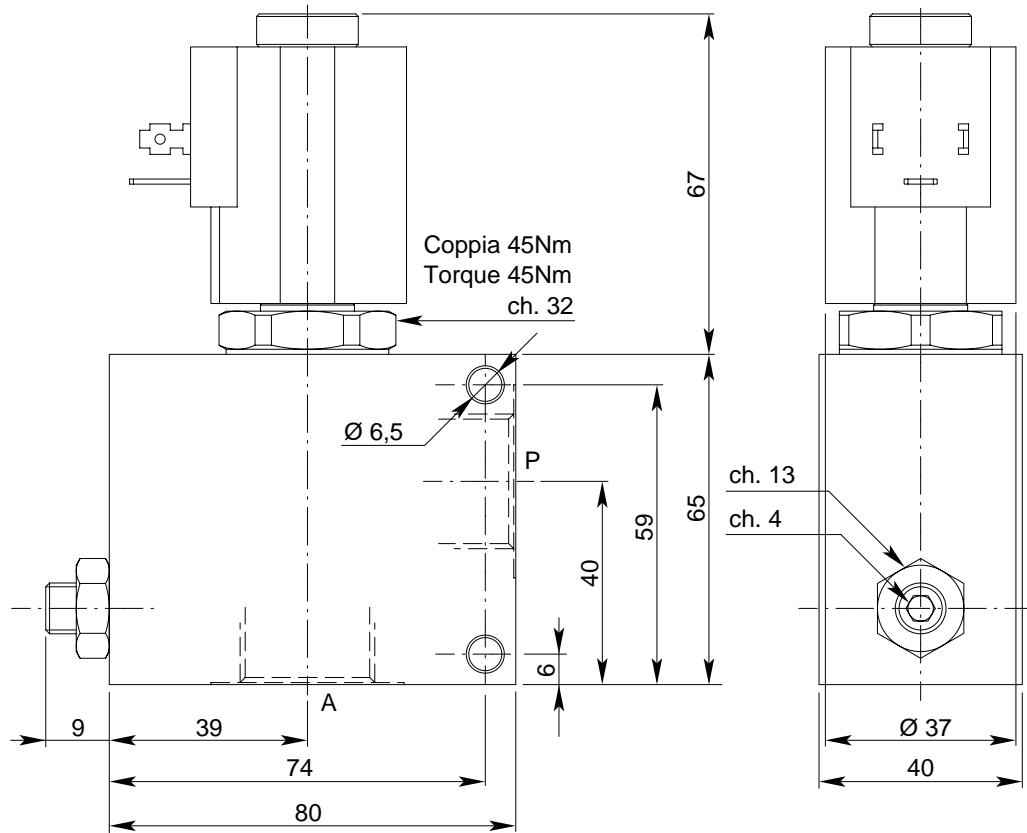

**Sigla di ordinazione / Ordering code**

**EV70 - 12 - A - VE**

Modello / Type

I dati non sono impegnativi, **CBF** si riserva di apportare modifiche senza preavviso.  
The specifications are not binding, **CBF** reserves the right to introduce modifications without notice.



**Valvola elettrica 2 vie unidirezionale pilotata - a cartuccia**  
**Two ways pilot operated electric valve - cartridge style**  
**mod. EV150 - C**

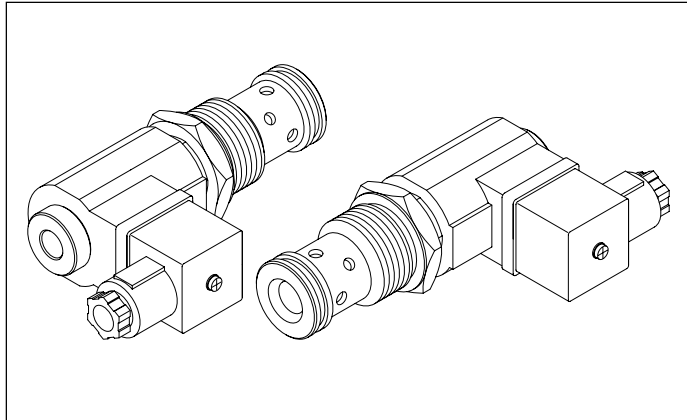

Cod.	Schema Symbol	Funzioni possibili con solenoide: Operating features with solenoid:	
		diseccitato de-energized	eccitato energized
<b>A</b>		P → A A → P	P → A A → P
<b>B</b>		P → A A → P	P → A A → P
<b>M</b>		P → A A → P	P → A A → P

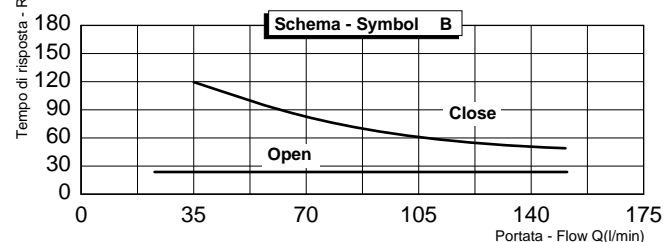
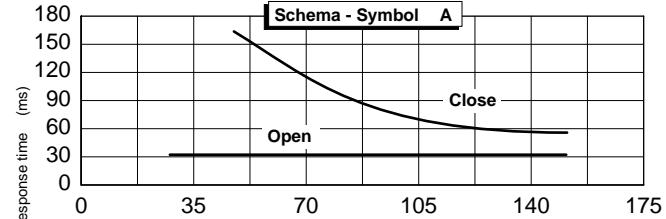
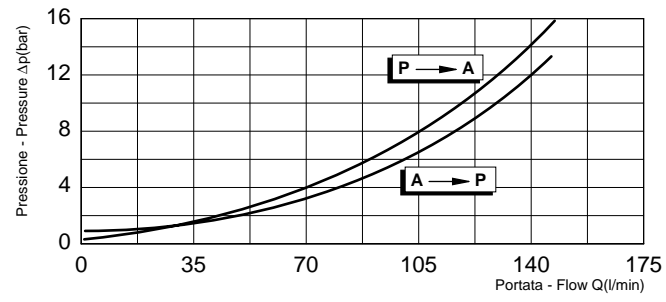

Modello EV150-C Type EV150-C	Pressione massima Max pressure bar	Portata max Max flow l / min
Schema - Symbol A	300	150
Schema - Symbol B		
Schema - Symbol M		

**Sigla di ordinazione / Ordering code**

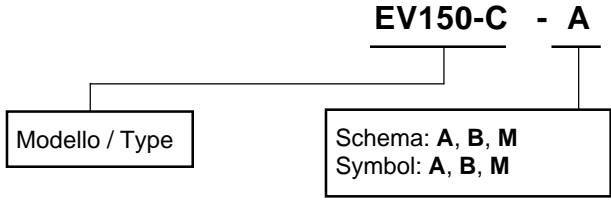

Tutti i dati forniti sono stati ottenuti usando olio con viscosità di circa 30 cSt a 50 °C. Campo di temperatura ammesso: -20 °C, +90 °C. Filtrazione assoluta: 25µ.  
 I dati non sono impegnativi, **CBF** si riserva di apportare modifiche senza preavviso.  
*All performances and calibrations are carried out by using hydraulic oil with viscosity approx. 30 cSt at 50 °C. Temperature range: -20 °C, +90 °C. Filtration absolute: 25µ.*  
*The specifications are not binding, CBF reserves the right to introduce modifications without notice.*

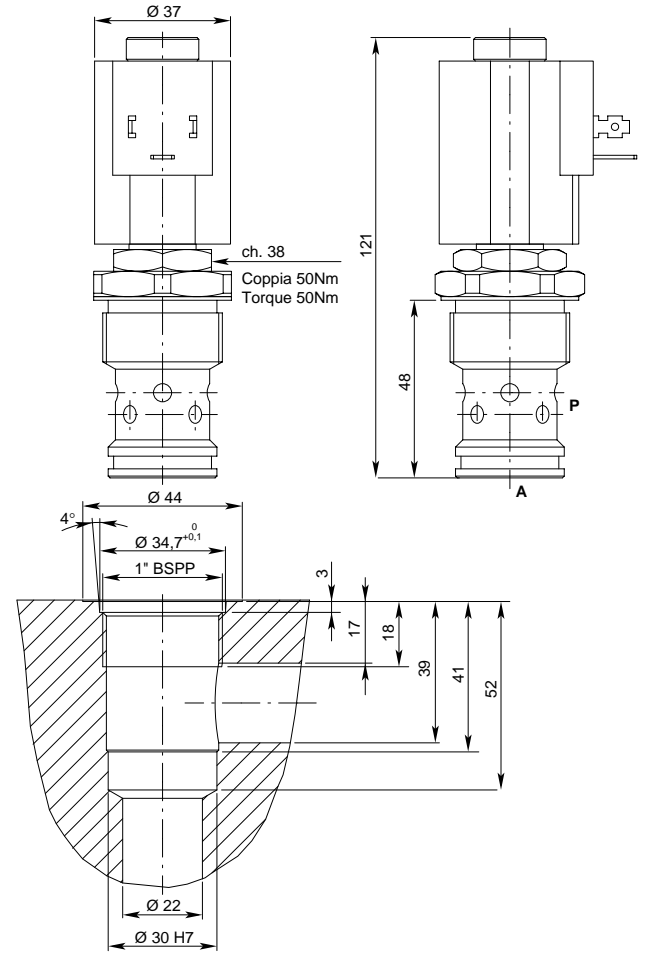

**Valvola elettrica 2 vie unidirezionale pilotata con o senza vite di emergenza**  
**Two ways pilot operated electric valve with or without emergency screw**  
**mod. EV150 / EV150VE**

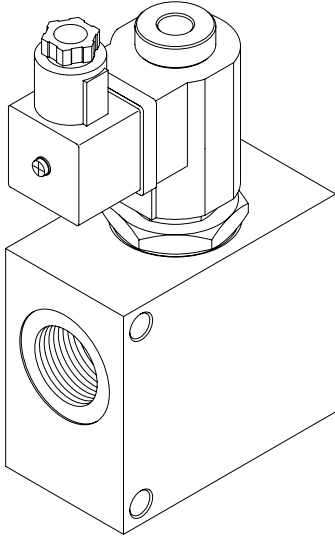

Cod.	Schema Symbol	Funzioni possibili con solenoide: Operating features with solenoid:	
		diseccitato de-energized	eccitato energized
<b>A</b>		P → A A → P	P → A A → P
<b>B</b>		P → A A → P	P → A A → P

Schema idraulico / Hydraulic scheme

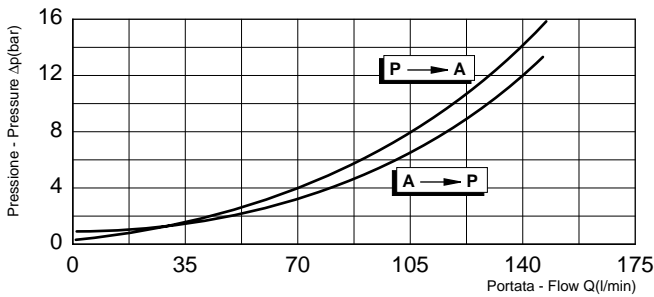

Tutti i dati forniti sono stati ottenuti usando olio con viscosità di circa 30 cSt a 50 °C. Campo di temperatura ammesso: -20 °C, +90 °C. Filtrazione assoluta: 25µ.  
 All performances and calibrations are carried out by using hydraulic oil with viscosity approx. 30 cSt at 50 °C. Temperature range: -20 °C, +90 °C. Filtration absolute: 25µ.

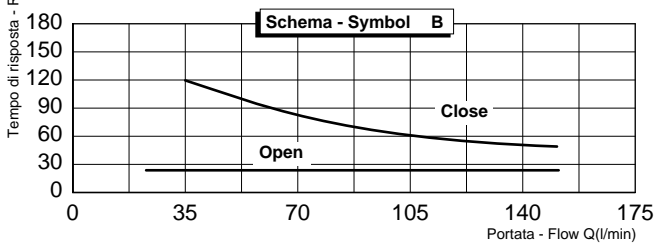
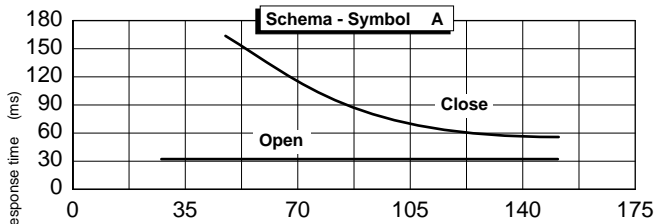

Modello Type	P A	Pressione massima Max pressure bar	Portata max Max flow l / min
EV150 - 34 / EV150 - 34 - VE	3/4" gas	300	150
EV150 - 10 / EV150 - 10 - VE	1" gas		

**Disegni / Drawings**

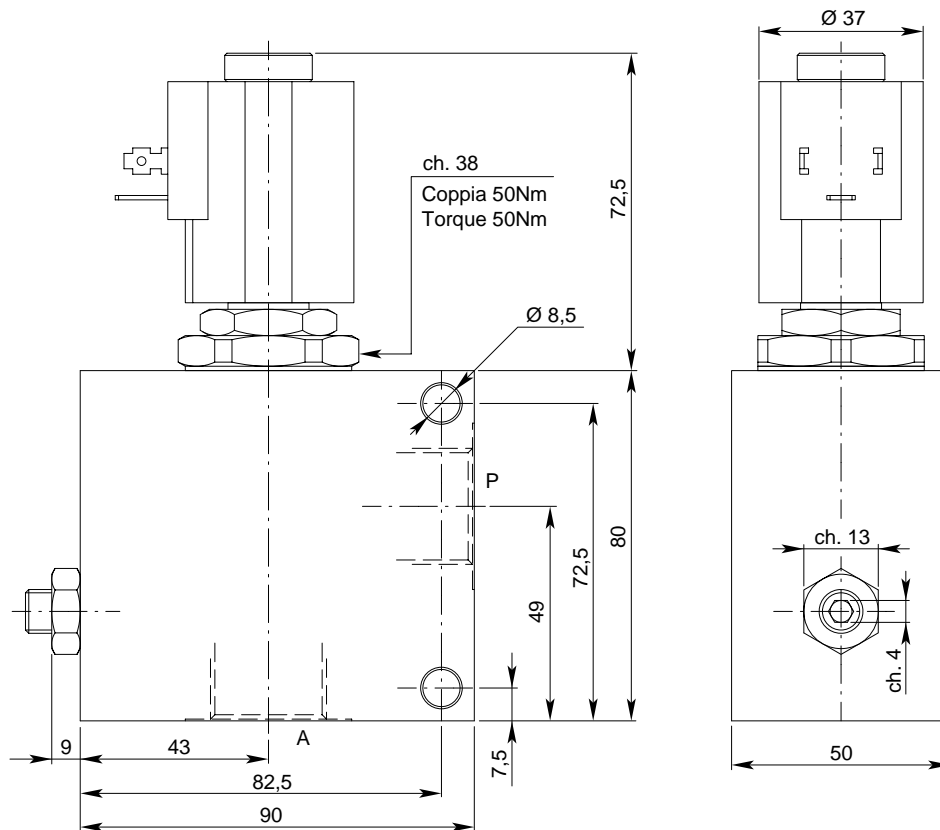

**Sigla di ordinazione / Ordering code**

**EV150 - 34 - B - VE**

Modello / Type

I dati non sono impegnativi, **CBF** si riserva di apportare modifiche senza preavviso.  
The specifications are not binding, **CBF** reserves the right to introduce modifications without notice.

